

SU-YC-SB4-OPEN-SP (OPEN Median Guard Rail)

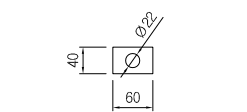
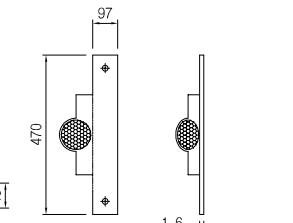
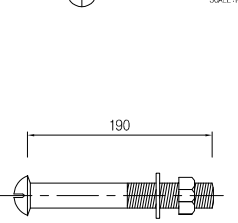
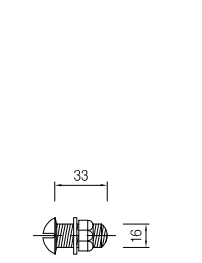
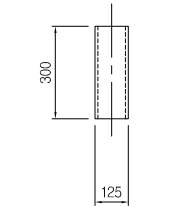
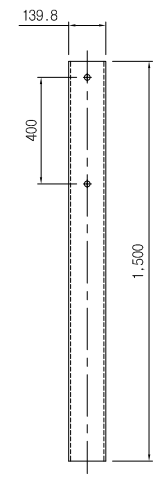
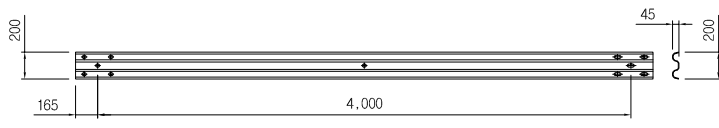
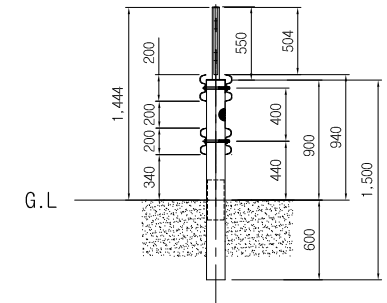
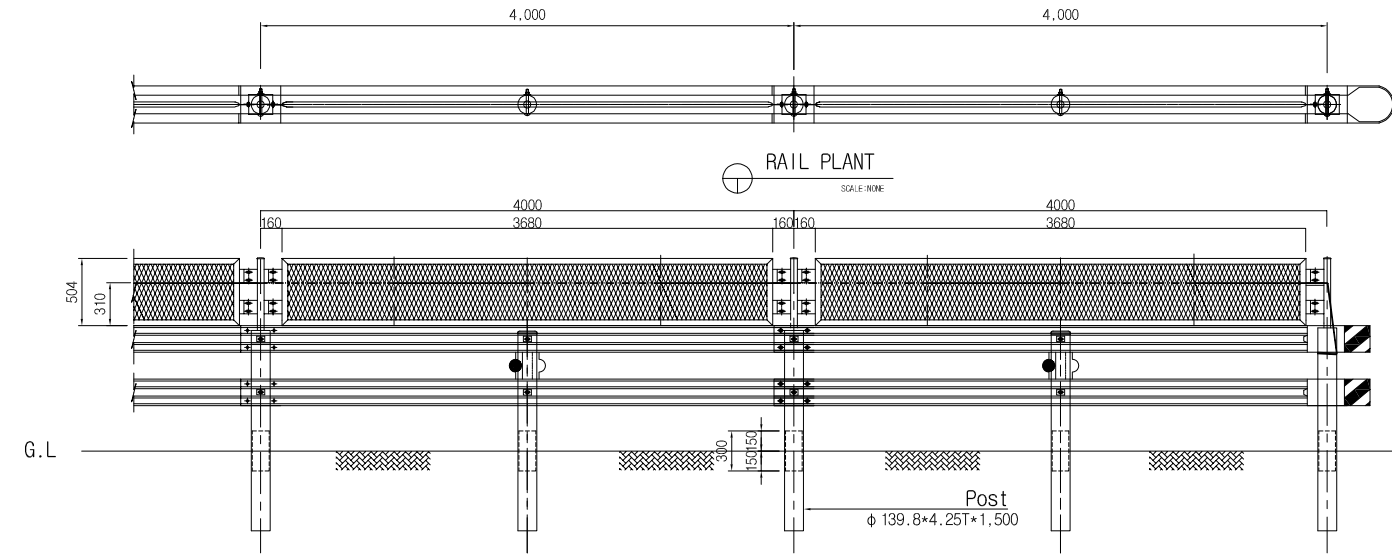

Standard Section(Per span)

Product Name	Dimension	Unit	Quantity	Remarks
YC Rail	3.1T*200*4,330	EA	2	SS275/POSMAC
Post	φ139.8*4.25T*1.500	EA	1	SGT275
Post RS	φ125*4.1T*300	EA	1	SGT275
CAP	φ139.8용	EA	0.5	
Square washer	40*60	EA	4	
Connection B/N	φ16*33	EA	8	
Mounting B/N	φ19*190	EA	2	
Reflection plate	1.6T*470	EA	1	SPHC
Light shielding net	Rectangular	SET	0.5	SPHC
wire rope	φ6	M	2	

*The wire rope intersects between the light shielding nets every 1M.

Drawing	SB4 Class	Design		date		Drawing number
Project		Drawing		scale		SU-YC-SB4-OPEN-SP(1)



**SUNGWON
ENC CO., LTD**

1st FL, 5 Yeonsudongsan-ro 7-gil (Yeonsu-dong),
Chungju-si, Chungcheongbuk-do, S. Korea
T E L 043-851-7717
F A X 0504-038-9103